

Gate Valve Outside Screw

PN 16 DN 50 - DN 800

Flanges PN 16 or PN 10



Fig. 210-510

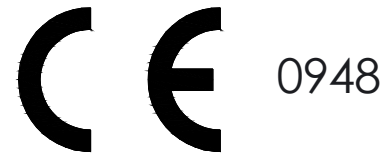
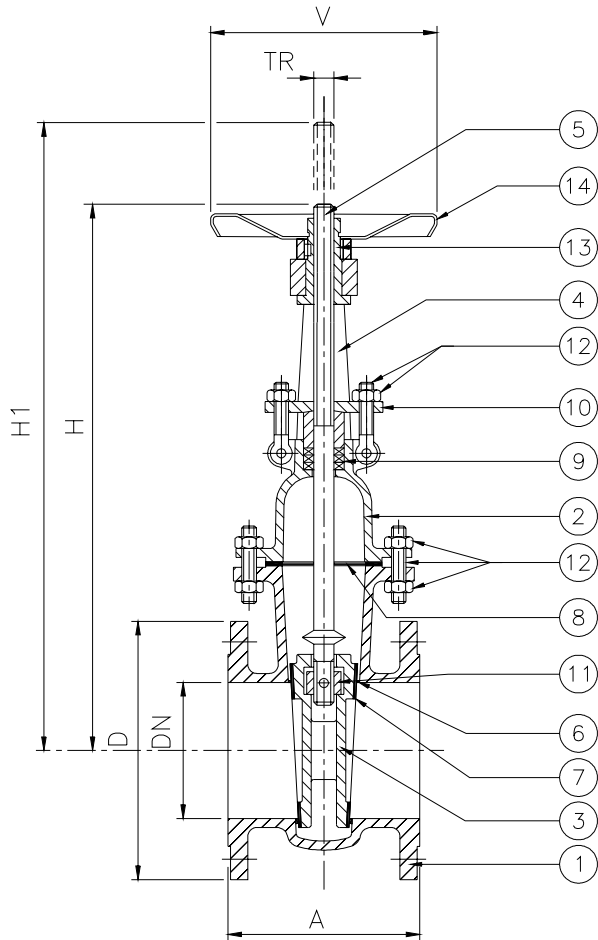

Standard features:

- Design EN 12516
EN 1984
- Face to face EN 558 series 14
DIN 3202 F4
- Flanges EN 1092-1/21/B1
- Materials EN 10213
EN 10269
EN 10088
- Bolts and nuts EN 1515-1
- Welding overlay AD-M HP 0
- Testing EN 1984
EN 12266
- Marking EN 19
- Certificates EN 10204

Optional versions:

- AD 2000 – A4
- TRD 110
- DIN 3230 Part 4
- DIN 3230 Part 5
- DIN 3230 Part 6
- TRbF 131
- TRbF 301 or 302
- ATEX
- TA-Luft
- With flanges PN 6
- With flanges form A, B2, C, D, E, F, G, H
- With butt welding ends (EN 12982 / EN 12627)
- With special devices (see pages 34 – 35)