

# Swing Check Valve

PN 100 DN 50 - DN 400

Flanges PN 100 or PN 63



Fig. 290-590

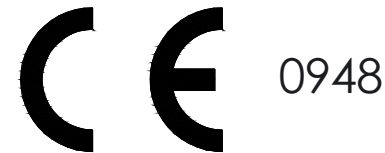
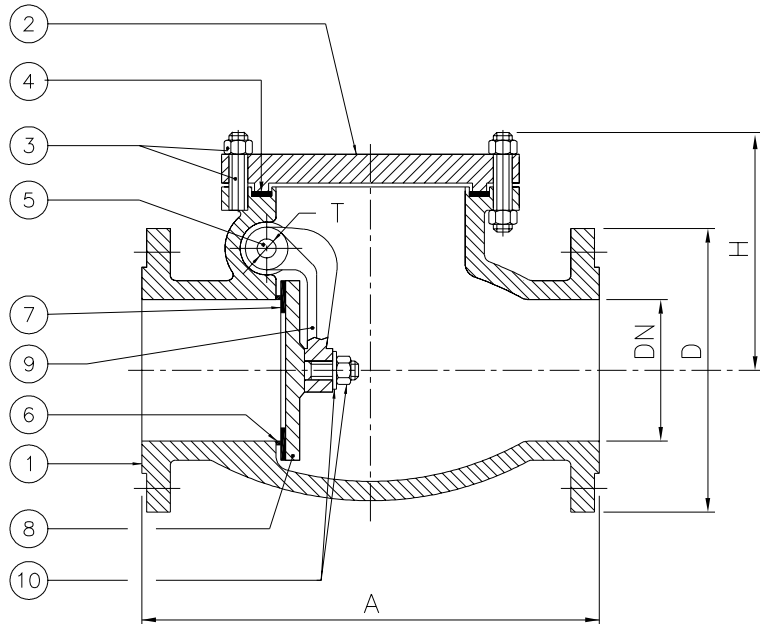

## Standard features:

- Design EN 12516  
EN 14341
- Face to face EN 558 series 2  
DIN 3202 F2
- Flanges EN 1092-1/21/B2
- Materials EN 10213  
EN 10269  
EN 10088
- Bolts and nuts EN 1515-1
- Welding overlay AD-M HP 0
- Testing EN 12266
- Marking EN 19
- Certificates EN 10204

## Optional versions:

- AD 2000 – A4
- TRD 110
- DIN 3230 Part 4
- DIN 3230 Part 5
- DIN 3230 Part 6
- TRbF 131
- TRbF 301 or 302
- ATEX
- TA-Luft
- With flanges PN 40 or PN25
- With flanges form A, B1, C, D, E, F, G, H
- With butt welding ends (EN 12627 / EN 12982)
- With special devices (see page 52)